

Measurement of enthalpies of sublimation by drop method in a Calvet type calorimeter: design and test of a new system

Luis M.N.B.F. Santos, Bernd Schröder, Oscar O.P. Fernandes, Manuel A.V. Ribeiro da Silva*

Centro de Investigação em Química, Departamento de Química, Faculdade de Ciências, Universidade do Porto, Rua do Campo Alegre 687, P-4169-007 Porto, Portugal

Received 12 May 2003; received in revised form 7 July 2003; accepted 8 July 2003

Available online 22 January 2004

Abstract

A new system to measure enthalpies of sublimation by the drop method was designed, constructed and tested. The performance of the apparatus was checked by measuring the enthalpy of sublimation of ferrocene, benzoic acid and anthracene at different temperatures. The measurement of enthalpies of sublimation by the drop method is described in detail.

Compound	$\langle T_{\text{exp}} \rangle$ (K)	$\langle \Delta_{\text{cr}}^{\text{g}} H_{\text{m}}^{\circ} \rangle$ at 298.15 K (kJ mol ⁻¹)
Benzoic acid	417	92.1 ± 2.6
Benzoic acid	453	93.9 ± 3.1
Ferrocene	373	74.9 ± 1.7
Anthracene	453	100.8 ± 1.7

© 2003 Elsevier B.V. All rights reserved.

Keywords: Enthalpies of sublimation; Drop method; Calvet microcalorimetry

1. Introduction

The enthalpy of sublimation, which is a measure of intermolecular forces in the crystalline phase [1], is an important thermodynamic property, which is necessary to derive the standard enthalpy of formation of a compound in the gaseous phase from its standard enthalpy of formation in the crystalline phase.

The experimental techniques to measure enthalpies of sublimation may be subdivided into direct and indirect methods [2–6]. While direct methods utilise appropriate calorimeters for determining enthalpies of sublimation, indirect methods mostly measure vapour pressures at different temperatures, since from the temperature dependence of the vapour pressure the enthalpy of sublimation may be derived.

Despite of the variety of methods available, enthalpies of sublimation are still scarce in the literature, and many of the reported literature values lack accuracy.

The technique described in this paper belongs to the direct methods. Tian–Calvet type heat-flux calorimeters that measure integral heats are suitable to determine enthalpies of sublimation. Tian [7] was one of the first scientists taking advantage of the heat conduction principle while constructing calorimeters. Multiple thermocouples connected to two thermoelectric piles, featuring a high thermal conductivity and sensitivity, surrounded the measuring chamber within a large calorimetric block of high heat capacity. The thermopiles measured the heat exchanged between the furnace and the sample cell, by compensation of the released heat, using the Peltier effect. The radial arrangement of the thermopiles provides a heat signal, which is nearly independent of local temperature distributions. Calvet [8a,8b] introduced a twin calorimeter made up from two identical Tian systems, symmetrically placed in the same thermostat, thus providing an effective compensation for irregular heat effects. Skinner and co-workers introduced the Calvet microcalorimetry drop-technique for the determination of enthalpies of sublimation, claiming an accuracy of the method within ±5% [9]. In this paper we describe a new system with the same principle, with improvements of the vacuum system and in the

* Corresponding author. Tel.: +351-22-6082-821; fax: +351-22-6082-822.

E-mail address: risilva@fc.up.pt (M.A.V. Ribeiro da Silva).

temperature measurement inside the cell, leading to more accurate values of the enthalpies of sublimation, limited only by the corrections for the heat capacities in gaseous phase.

2. Method description

2.1. Calorimetry

In the Calvet microcalorimetry drop-technique for the determination of enthalpies of sublimation, a capillary tube containing the sample and a capillary blank tube are simultaneously dropped into the hot-zone of the calorimeter. After the tubes have reached thermostability, the sample is removed from the hot-zone by vacuum. The total enthalpy change measured for the process

$$\Delta_{\text{cr},298.15\text{K}}^{\text{g},T} H_{\text{m}}^{\circ} \quad (1)$$

can be subdivided, as illustrated in Fig. 1, in two main terms: the enthalpy change due to the heating of the sample in the condensed state from $T = 298.15\text{K}$ to the hot-zone temperature T ,

$$\Delta H_{\text{m}} = \int_{298.15\text{K}}^T c_p(\text{cr}) dT, \quad (2)$$

and the enthalpy change corresponding to the sublimation of the sample at hot-zone temperature,

$$\Delta_{\text{cr}}^{\text{g}} H_{\text{m}}(T), \quad (3)$$

a third enthalpic term is concerned with blank heat capacity corrections. In terms of the heat capacity contributions, the heat capacities of the capillary tubes are not cancelling out each other totally, and their contributions are not negligible in the total enthalpy change. Therefore, due to the difference in the mass of both capillary tubes and also due to different sensibilities of the two measuring cells, blank heat capacity corrections have to be taken into account

$$\Delta_{\text{cr},298.15\text{K}}^{\text{g},T} H_{\text{m}}^{\circ} = \Delta H_{\text{total}} - \Delta H_{\text{corr}}(\text{blank}) \quad (4)$$

with $\Delta H_{\text{corr}}(\text{blank})$ being a function of the hot-zone temperature and of the masses of the blank (m_{ref}) and of the empty experimental capillary tube (m_{exp}).

To minimise the errors resulting from this procedure, the masses of the blank, m_{ref} , and of the experimental capillary tube, m_{exp} , should be as similar as possible.

The standard molar enthalpy of sublimation at $T = 298.15\text{K}$, $\Delta_{\text{cr}}^{\text{g}} H_{\text{m}}^{\circ}$, may be derived from the total enthalpy change measured for the process using the following equation:

$$\Delta_{\text{cr}}^{\text{g}} H_{\text{m}}^{\circ} = \Delta_{\text{cr},298.15\text{K}}^{\text{g},T} H_{\text{m}}^{\circ} - \{H_{\text{m}}^{\circ}(\text{g}, T) - H_{\text{m}}^{\circ}(\text{g}, 298.15\text{K})\} \quad (5)$$

with $\{H_{\text{m}}^{\circ}(\text{g}, T) - H_{\text{m}}^{\circ}(\text{g}, 298.15\text{K})\}$ representing the molar enthalpic correction for the respective heat capacity of the gaseous phase.

3. Experimental

3.1. Operation of apparatus

3.1.1. Calorimeter

The scheme of the whole system is shown in Fig. 2. A Calvet type microcalorimeter (Setaram, model HT1000D) with a sensitivity of $3\mu\text{V mW}^{-1}$ is utilised in the system. The sensitive part of this calorimeter is the conduction device, which connects the outer wall of the measuring chamber to the isothermal block, with heaters placed under the base and on top of the block to archive a uniform temperature distribution in this high-temperature version of the calorimeter. This device is composed of 496 thermocouples (Pt–Pt/Rh), which are assembled in 16 sheets, each of them containing 31 thermocouples, radially covering the measuring chamber in vertical arrays. The hot-zone of the HT1000D microcalorimeter is reached from the top of the calorimeter through open shafts, allowing the sample and the reference vessels to be moved from the outside.

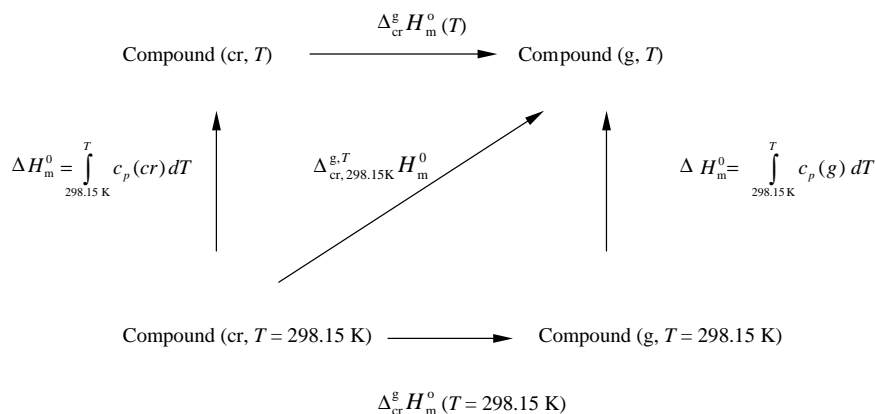

Fig. 1. Thermochemical cycle of the sublimation experiment.

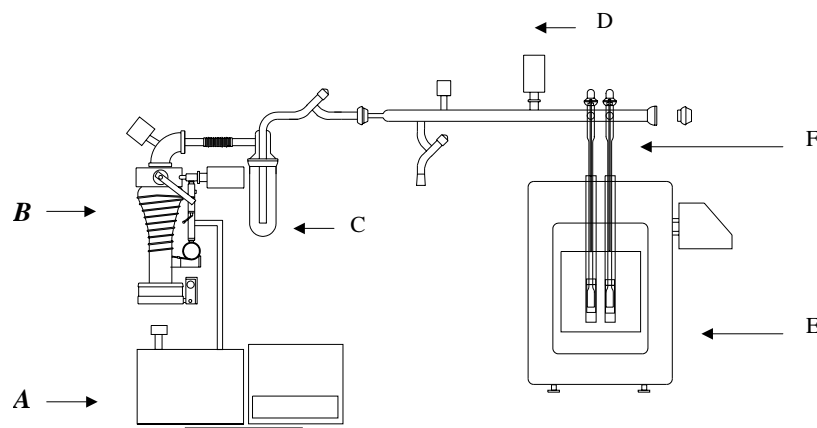

Fig. 2. Schematic view of the Calvet drop method assembly, consisting of the vacuum line and a Calvet microcalorimeter Setaram, model HT1000D: A (rotary vacuum pump); B (diffusion pump); C (liquid nitrogen glass trap); D (Pirani and Penning gauges); E (HT1000D calorimeter block); F (calorimetric cells).

The G11 system controller is used as a temperature controller, for temperature monitoring and for thermopile sign amplification and digitalisation. Data acquisition and analysis (Setaram 3.20) is done via an interfaced computer.

As a result of the observed heat flux in the reference and the sample cells, the signal obtained from the output of the calorimeter is a difference in potential, given in μV . Calibrations at different temperatures enable the conversion into a unit of power [10]:

$$\phi \text{ (mW)} = \frac{\phi \text{ (}\mu\text{V)}}{S}, \quad (6)$$

where S is the sensibility coefficient given as

$$S = 2.17663 + 7.76923 \times 10^{-3} \times \theta - 2.58323 \times 10^{-5} \times \theta^2 + 3.23784 \times 10^{-8} \times \theta^3 - 1.46329 \times 10^{-11} \times \theta^4$$

with θ as the temperature of the hot-zone in $^{\circ}\text{C}$.

3.2. Hot-zone temperature calibration

The hot-zone temperature was calibrated in situ, using a miniature Pt 100 temperature sensor, class A 1/10 (Labfacility). Beforehand, in accordance to the International Temperature Scale of 1990, ITS-90, this sensor was calibrated against a SPRT (25 ohm; Tinsley, 5187A) temperature probe using an ASL bridge model F26.

The relation between the real temperature of the cells in the hot-zone, θ_{Real} ($^{\circ}\text{C}$), and the respective temperature indicated by the G11 controller, θ_{G11} ($^{\circ}\text{C}$), is as follows:

$$\theta_{\text{Real}} = 1.0054\theta_{\text{G11}} - 3.822. \quad (7)$$

3.3. Vacuum line system

The pumping system consists of one rotary vacuum pump (Edwards, model RV5), which is used both for pre-evacuating the system and for backing the vapour diffusion pump (Edwards, model Diffstak 63). A Pirani gauge

(Edwards, model APG-M) is used to measure the vacuum in the system during the pre-evacuation process. A Penning gauge (Edwards, model AIM-S) is used to measure the vacuum maintained in the system throughout the sublimation process. The vacuum line is connected to the pumping system through a glass cold trap, which can be filled with liquid nitrogen. All glass connections in the system are made of greaseless spherical joints from Young.

3.4. Calorimetric cells

The calorimetric cells, shown in Figs. 3 and 4, are Pyrex glass cylinders of internal diameter 12 mm and depth 50 mm. They are embedded in identical cylinders made of Kanthal (Fig. 4), thus providing good thermal contact in the hot-zone. Rejuvenated prolongations of the glass cylinders are leaving the hot-zone and assure the connection to the vacuum line; tunnelling tubes allow repeating the mea-

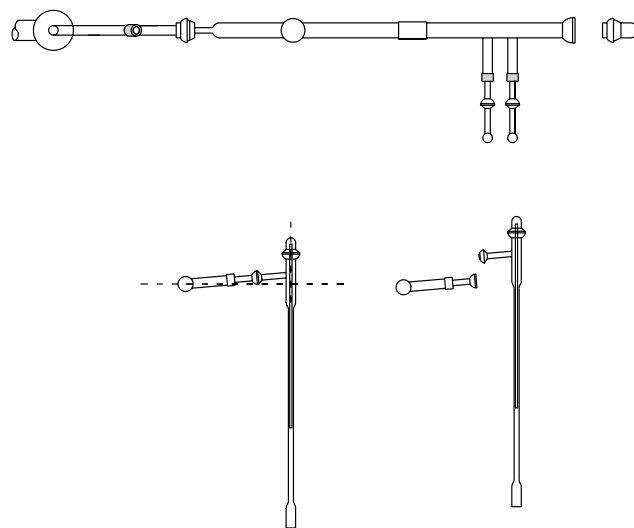

Fig. 3. Top view of the glass parts of the vacuum line and details of the calorimetric cell assembly.

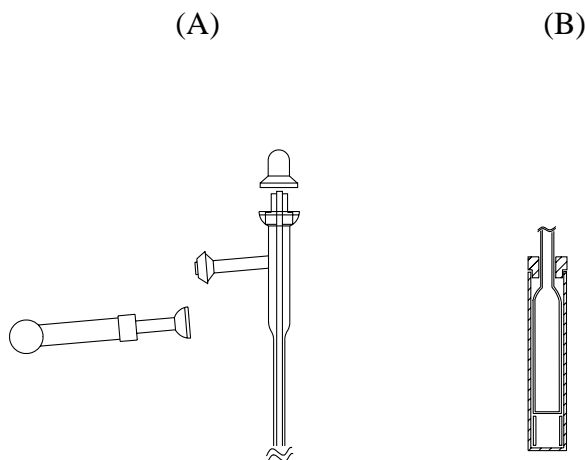

Fig. 4. Top of the calorimetric cell with the tunnelling tube (A) and the bottom of the calorimetric cell with Pyrex glass cylinder, centring glass support and Kanthal cylinder (B).

measurements without removing the cells from the hot-zone (less volatile compounds tend to crystallise on the walls of cooler sections of the prolongation tube, thus making multiple measurements impossible). The tunnelling tubes are easy removed and cleaned, without disturbing the thermal equilibrium of the cells.

3.5. Experimental technique

After providing appropriate blank as well as experimental capillary tubes, the mass of both of them is determined: m_{ref} ,

m_{exp} (microbalance Mettler-Toledo, model UMT 2) with a resolution of $\pm 0.1 \mu\text{g}$.

The powdered sample is charged into the thin experimental capillary tube (sealed at one end), and weighted again ($m_{\text{exp+sample}}$). Samples of about 5 mg of compound are dropped simultaneously with the corresponding blank tube at $T = 298.15 \text{ K}$ (after stabilising its temperature) by means of a sample holder made of an aluminium block into the hot reaction vessel in the Calvet microcalorimeter, held at the hot-zone temperature. After the tubes reached thermostability, the sample is removed from the hot-zone by sublimation into the vacuum.

Preliminary sublimation experiments in connection with DSC studies (Setaram, model DSC 141) with the compounds under test were performed so as to verify the most appropriate hot-zone temperature.

A typical curve obtained from a sublimation experiment is shown in Fig. 5.

3.6. Blank experiments

As stated before, due to differences in the mass of both capillary tubes and due to different sensibilities of the two measuring cells towards heat perturbations, blank heat capacity corrections were performed. The range of acceptable capillary tube mass was predefined by individual blank correction experiments (between 20 and 30 mg).

In the blank experiments, (empty) blank capillary tubes were dropped in both the sample and the reference cell and the resulting enthalpic sign was recorded.

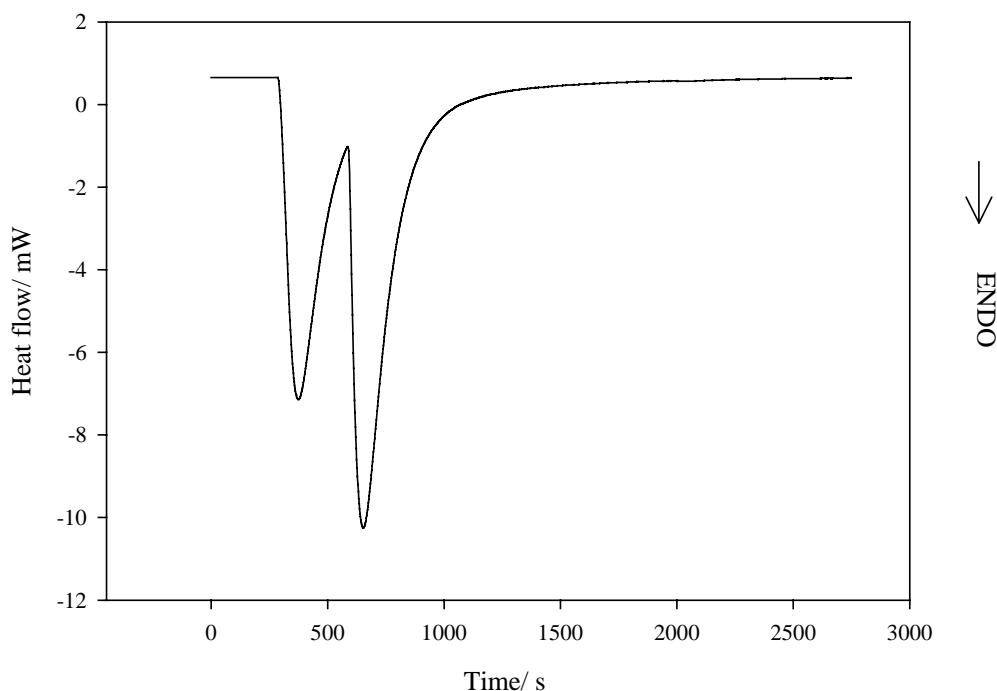

Fig. 5. A typical curve obtained from a sublimation experiment.

Table 1
Typical calibration results for the Calvet microcalorimeter with naphthalene at $T = 373$ K

Experiment number	m_{exp} (mg)	$m_{\text{exp+sample}}$ (mg)	m_{ref} (mg)	$\Delta H_{\text{corr}}(\text{blank})$ (mJ)	Enthalpy calculated (J)	k^a
1	25.607	32.940	25.779	2.4	4.8721	0.9893
2	24.115	30.555	24.351	14.5	4.2932	0.9834
3	22.089	27.483	22.540	38.7	3.5644	0.9846
4	24.114	30.410	24.352	14.4	4.1638	0.9911
5	25.785	32.211	25.564	−24.2	4.3056	0.9872

^a $\langle k \rangle = 0.9871 \pm 0.0079$.

In order to derive the dependency of the enthalpic blank correction, $\Delta H_{\text{corr}}(\text{blank})$, as a function of the hot-zone temperature, T , and of the masses of the blank (m_{ref}) and of the experimental capillary tube (m_{exp}), 60 blank experiments were performed, and a linear, semi-empirical model was applied: $\Delta H_{\text{corr}}(\text{blank})$ (mJ) = $a + (bm_{\text{exp}} + cm_{\text{ref}})(T - 298.15) + d(T - 298.15)$ with $a = -20.3902$, $b = -0.88204$, $c = 0.816818$, $d = 1.814894$, and m_{exp} , m_{ref} being the masses of the experiment and reference tube (in mg); the standard deviation of the fitting is better than ± 20 mJ.

3.7. Calibrations and measurements

The Calvet microcalorimeter for the determination of enthalpies of sublimation was calibrated at different temperatures, using recommended primary standards [11] as well as appropriate test substances. The values for $\{H_{\text{m}}^{\circ}(\text{g}, T) - H_{\text{m}}^{\circ}(\text{g}, 298.15 \text{ K})\}$, representing the molar enthalpic correction for the respective heat capacity of the gaseous phase, could be derived from heat capacity measurements or, in the case of lack of literature data, estimated by the group additivity method described by Stull et al. [12].

Naphthalene (Aldrich, scintillation grade) as the calibrant for the whole temperature range was purified by sublimation under vacuum followed by zone-melting. The value for $\{H_{\text{m}}^{\circ}(\text{g}, T) - H_{\text{m}}^{\circ}(\text{g}, 298.15 \text{ K})\}$ was interpolated using a third-order polynomial fitting on the values of Stull et al. [12].

Benzoic acid, primary reference material (Bureau of Analysed Samples; Thermochemical Standard BCS-CRM 190-r) was used without further purification. The value for $\{H_{\text{m}}^{\circ}(\text{g}, T) - H_{\text{m}}^{\circ}(\text{g}, 298.15 \text{ K})\}$ was interpolated using a third-order polynomial fitting on the values of Stull et al. [12].

Ferrocene, primary reference material (Janssen Chimica) was purified by recrystallisation and repeated sublimation under vacuum. The value for $\{H_{\text{m}}^{\circ}(\text{g}, T) - H_{\text{m}}^{\circ}(\text{g}, 298.15 \text{ K})\}$ was derived using results from heat capacity measurements [13].

Anthracene, primary reference material (Aldrich, 99%) was purified by sublimation under vacuum. The value for $\{H_{\text{m}}^{\circ}(\text{g}, T) - H_{\text{m}}^{\circ}(\text{g}, 298.15 \text{ K})\}$ was derived using heat capacity measurements [14].

The relative atomic masses used were those recommended by the IUPAC Commission in 1999 [15].

4. Results and discussion

Table 1 lists typical calibration results with naphthalene at $T = 373$ and Table 2 lists the individual calibrations results for $T = 373$, 417 and 453 K using the recommended enthalpy of sublimation of naphthalene, $\Delta_{\text{cr}}^{\text{g}} H_{\text{m}}^{\circ} = 72.600 \pm 0.600 \text{ kJ mol}^{-1}$ [11].

The individual results of the measurements of the total enthalpy changes in the sublimation experiment, $\Delta_{\text{cr}, 298.15 \text{ K}}^{\text{g}, T} H_{\text{m}}^{\circ}$, for benzoic acid ($T = 417$ and 453 K), ferrocene ($T = 373$ K) and anthracene ($T = 453$ K), are given in Table 3.

Table 2
Individual calibration results with naphthalene at different hot-zone temperatures

$T = 373$ K	$T = 417$ K	$T = 453$ K
0.9893	0.9833	0.9891
0.9834	0.9795	0.9801
0.9846	0.9863	0.9914
0.9911	0.9874	1.0047
0.9872	0.9794	1.0119
		1.0102
		0.9815
		1.0083
		1.0066
		0.9973
		1.0005
		1.0061
		1.0039
0.9871 ± 0.0079^a	0.9832 ± 0.0075^a	0.9994 ± 0.0109^a

^a The values are for $\langle k \rangle$.

Table 3
Individual experimental results for the total enthalpy change, $\Delta_{\text{cr}, 298.15 \text{ K}}^{\text{g}, T} H_{\text{m}}^{\circ}$

Benzoic acid		Ferrocene	Anthracene
$T = 417$ K	$T = 453$ K	$T = 373$ K	$T = 453$ K
106.69	112.43	87.42	135.57
107.12	114.91	87.68	136.64
107.23	110.98	89.86	138.11
107.40	116.04	86.93	136.23
106.26	115.22	88.80	136.02
	114.72	86.97	
106.94 ± 0.41^a	114.1 ± 1.6^a	87.9 ± 1.0^a	136.51 ± 0.87^a

^a The values are for $\langle \Delta_{\text{cr}, 298.15 \text{ K}}^{\text{g}, T} H_{\text{m}}^{\circ} \rangle$ in kJ mol^{-1} .

Table 4

The total enthalpy change, $\langle \Delta_{\text{cr}, 298.15 \text{ K}}^{\text{g}, T} H_{\text{m}}^{\circ} \rangle$, the applied molar enthalpic corrections for the heat capacity of the gaseous phase, $\{H_{\text{m}}^{\circ}(\text{g}, T) - H_{\text{m}}^{\circ}(\text{g}, 298.15 \text{ K})\}$, and the derived standard molar enthalpies of sublimation at $T = 298.15 \text{ K}$, $\langle \Delta_{\text{cr}}^{\text{g}} H_{\text{m}}^{\circ} \rangle$

Compound	$\langle T_{\text{exp}} \rangle$ (K)	$\langle \Delta_{\text{cr}, 298.15 \text{ K}}^{\text{g}, T} H_{\text{m}}^{\circ} \rangle$ (kJ mol ⁻¹)	$\{H_{\text{m}}^{\circ}(\text{g}, T) - H_{\text{m}}^{\circ}(\text{g}, 298.15 \text{ K})\}$	$\langle \Delta_{\text{cr}}^{\text{g}} H_{\text{m}}^{\circ} \rangle$ (kJ mol ⁻¹)
Benzoic acid	417	106.94 ± 0.41	14.8 ± 2.5 [12]	92.1 ± 2.6
Benzoic acid	453	114.1 ± 1.6	20.2 ± 2.5 [12]	93.9 ± 3.1
Ferrocene	373	87.9 ± 1.0	13.0 ± 1.0 [13]	74.9 ± 1.6
Anthracene	453	136.51 ± 0.87	35.7 ± 1.0 [14]	100.8 ± 1.7

Table 4 lists the derived standard molar enthalpies of sublimation of the compounds under test, as well as the considered values for the $\{H_{\text{m}}^{\circ}(\text{g}, T) - H_{\text{m}}^{\circ}(\text{g}, 298.15 \text{ K})\}$ representing the molar enthalpic corrections. The values of $\{H_{\text{m}}^{\circ}(\text{g}, T) - H_{\text{m}}^{\circ}(\text{g}, 298.15 \text{ K})\}$ for benzoic acid, have been taken from the compilation of Stull et al. [12], where it is clearly stated that they are derived from a provisional assignment of the vibrational frequencies and so may be not very accurate. This can introduce an additional uncertainty in the values derived using the data of Stull et al., which can explain the larger deviations between the recommended and the experimental values of the enthalpies of sublimation in the case of benzoic acid, a thing that does not occur in the case of anthracene and ferrocene.

The assigned uncertainties are twice the overall standard deviation of the mean and include the uncertainties in calibration.

For benzoic acid, anthracene and ferrocene, a variety of experimental values exists, being subject of critical data analysis [11,16]. In Table 5, recommended values for the standard molar enthalpies of sublimation at $T = 298.15 \text{ K}$, $\Delta_{\text{cr}}^{\text{g}} H_{\text{m}}^{\circ}$ of the primary reference materials benzoic acid, anthracene and ferrocene, are registered. A comparison with the results obtained in this work suggests a good agreement.

The tests with benzoic acid, ferrocene and anthracene indicate that the Calvet microcalorimetry drop-technique enables accurate determination of enthalpies of sublimation with small amounts of a sample having a sufficient vapour pressure. The agreement of the observed and recommended

Table 5

Standard molar enthalpies of sublimation, $\Delta_{\text{cr}}^{\text{g}} H_{\text{m}}^{\circ}$, of the primary reference materials benzoic acid, anthracene and ferrocene, at $T = 298.15 \text{ K}$

Compound	$\Delta_{\text{cr}}^{\text{g}} H_{\text{m}}^{\circ}$ at 298.15 K (kJ mol ⁻¹)	
	This work	Recommended value [11]
Benzoic acid	92.1 ± 2.6 93.9 ± 3.1	89.70 ± 1.00
Anthracene	100.8 ± 1.7	103.36 ± 2.67
Ferrocene	74.9 ± 1.6	73.42 ± 1.08

values supports the reliability of the calorimeter and the adopted experimental procedure as a whole.

The uncertainty of the method lies within ±2%, being limited by the purity and thermal stability of the compound under test, as well as by the uncertainty introduced by the heat capacity corrections. This method has the advantage of using small amounts of sample and yielding results in a reasonable short time.

Acknowledgements

Thanks are due to Fundação Para a Ciência e Tecnologia, Lisboa, Portugal, for financial support through Centro de Investigação em Química da Universidade do Porto (Linha 5); Bernd Schröder thanks for the award of a post-doc scholarship (BPD 35131/2000).

References

- [1] J.D. Cox, G. Pilcher, *Thermochemistry of Organic and Organometallic Compounds*, Academic Press, New York, 1970.
- [2] G.W. Thomson, Determination of vapour pressure, in: A. Weissberger (Ed.), *Technique of Organic Chemistry*, Part 1, 3rd ed., Interscience, New York, 1965, pp. 401–522.
- [3] S. Dushman, *Scientific Foundations of Vacuum Technique*, 2nd ed., Wiley, New York, 1962.
- [4] R. Cooper, D.R. Stranks, Vapour pressure measurements, in: A. Weissberger (Ed.), *Technique of Inorganic Chemistry*, Interscience, New York, 1966, pp. 1–83.
- [5] C.G. De Kruif, The use of a simultaneous torsion and mass-loss effusion apparatus for determining vapour pressures and enthalpies of sublimation, in: M.A.V. Ribeiro da Silva (Ed.), *Thermochemistry and its Applications to Chemical and Biological Systems*, NATO ASI Series, Series C, vol. 119, Reidel, Dordrecht, 1984, pp. 143–155.
- [6] M.A.V. Ribeiro da Silva, M.L.S. Monte, *Thermochim. Acta* 171 (1990) 169–183.
- [7] A. Tian, *Bull. Soc. Chim. Fr. Ser. 4* (33) (1923) 427.
- [8] (a) E. Calvet, *C.R. Acad. Science (Paris)* 226 (1948) 1702; (b) E. Calvet, H. Prat, *Recent Progress in Microcalorimetry*, Pergamon Press, New York, 1983.
- [9] F.A. Adedeji, D.L.S. Brown, J.A. Connor, M. Leung, M.I. Paz-Andrade, H.A. Skinner, *J. Organomet. Chem.* 97 (1975) 221–228.
- [10] Setaram, *Service Manual*, model HT1000 D-B/07NECALOA, France, 1992.
- [11] R. Sabbah, An. Xu-Wu, J.S. Chickos, M.L. Planas Leitão, M.V. Roux, L.A. Torres, *Thermochim. Acta* 331 (1999) 93–208.
- [12] D.R. Stull, E.F. Westrum, G.C. Sinke, *The Chemical Thermodynamics of Organic Compounds*, Wiley, New York, 1969.
- [13] A.G. Turnbull, *Aust. J. Chem.* 20 (1967) 2059–2067.
- [14] Glushko Thermocenter, Russian Academy of Sciences (V.S. Yungman, director), *Entropy and heat capacity of organic compounds*, in: P.J. Linstrom, W.G. Mallard (Eds.), *NIST Chemistry WebBook*, NIST Standard Reference Database No. 69, National Institute of Standards and Technology, Gaithersburg, MD, March 2003. <http://webbook.nist.gov>.
- [15] T.B. Coplen, *J. Phys. Chem. Ref. Data* 30 (3) (2001) 701–712.
- [16] J.S. Chickos, W.E. Acree, *J. Phys. Chem. Ref. Data* 31 (2) (2002) 537–698.